

KESTON

Boilers

High Efficiency Domestic & Commercial Boilers
34 West Common Road Hayes Bromley Kent BR2 7BX
Telephone : 020 8462 0262 Fax : 020 8462 4459
e-mail: info@keston.co.uk Web: www.keston.co.uk

DUAL BOILER SCHEMATIC DESIGN

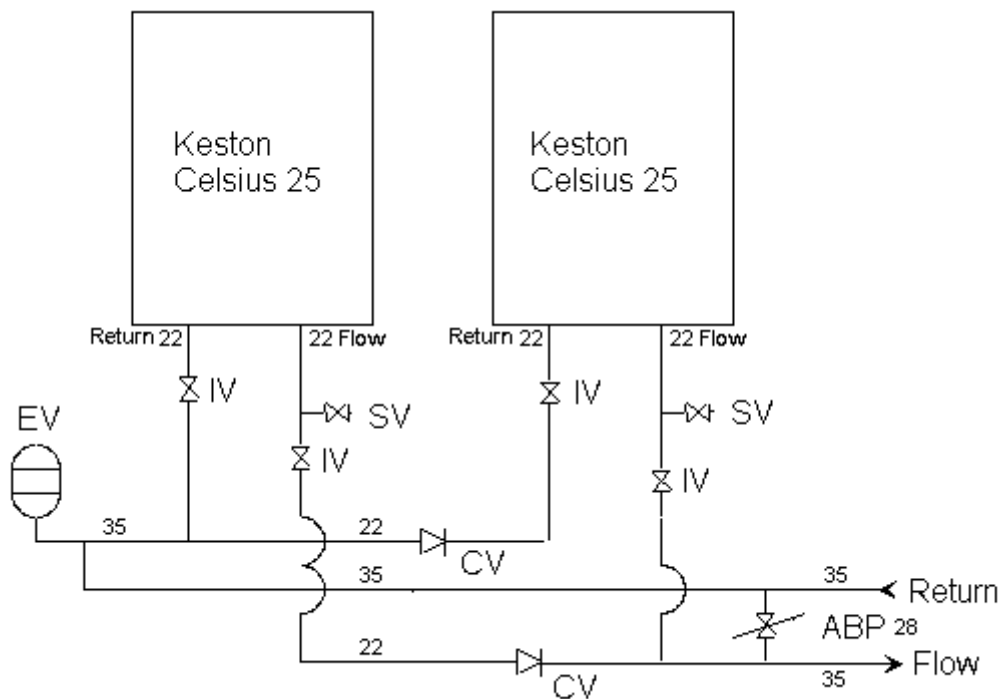

Key:

EV	Expansion Vessel
AAV	Automatic Air Vent
IV	Isolating Valve
SV	Safety Valve
CV	Check Valve
ABP	Auto By-Pass Valve

Assumptions.

1. The System resistance is within the spare capacity of the boiler pumps. Otherwise consideration should be given to the use of an additional System pump.